



# CARGO AIRCRAFT GUIDE

Volga  Dnepr

 AIRBRIDGECARGO

 ATRAN



# WE WORK WITH WORLD LEADERS

For over 30 years, Volga-Dnepr Group's unique aircraft fleet has been advancing the world of air cargo logistics, enabling our global customers to achieve fast, secure and cost-efficient transportation solutions, even for their most complex logistics challenges.

Volga-Dnepr Group started with Volga-Dnepr Airlines in 1990 when its first An-124-100 departed on its inaugural charter flight. Since then, with more than three decades of successful operations, Volga-Dnepr gradually evolved into the Volga-Dnepr Group. Consisting of three international air cargo carriers, the Group provides its customers with **reliable and cost-efficient solutions for even the most complex cargo projects**, supporting various industries including Aerospace, Oil and Gas, Automotive, Energy and beyond.





## OUR GROUP

Volga-Dnepr unities **around 4,000 cargo professionals across the globe** who work under various aspects of cargo transportation to **guarantee a seamless customer experience for you.**

### TODAY, Volga-Dnepr offers:

#### CARGO CHARTER OPERATIONS

delivered by three cargo carriers within the Group (Volga-Dnepr Airlines, AirBridgeCargo Airlines, ATRAN Airlines) onboard ramp An-124-100/150, IL-76TD-90VD, Boeing 400ERF/8F, B777F and Boeing 737-400SF/800BCF.

#### SCHEDULED CARGO OPERATIONS

delivered by AirBridgeCargo Airlines and ATRAN Airlines onboard Boeing 747, 777 and Boeing 737 freighters between Russia, Asia, the Middle East, Europe and North America. The combined network of both carriers covers more than 40 destinations worldwide, with all flights operated into international cargo hubs offering fast, efficient and secure handling of any type of cargo.

#### SUPPORTING SERVICES

in the field of

- MRO
- logistics services
- training
- insurance
- trucking

10

AN-124-100

2

AN-124-150

5

IL-76TD-90VD

17

Boeing 747F

1

Boeing 777F

5

Boeing 737F



## AIRCRAFT SPECIFICATION

# AN-124-100/150

The An-124-100 is the **world's largest, mass produced, civil cargo aircraft** and is a recognized leader of the air cargo industry for its ability to transport oversized and super-heavy shipments.

The combination of exceptional characteristics such as its cargo compartment size, flight range and uplift capability (without the need for special loading equipment) allows the **An-124** to carry super-heavy and oversized **cargoes including equipment up to 120 tonnes** (An-124-100) and **up to 150 tonnes** (An-124-150).

	AN-124-100	AN-124-150
ENGINE TYPE	4x Lotarev D-18 T	4x Lotarev D-18 T
ENGINE TAKE-OFF THRUST	4x 24 T $\Sigma$ = 96 T	4x 24 T $\Sigma$ = 96 T
MAXIMUM TAKE-OFF WEIGHT	392,000 kg	402,000 kg
OPERATING EMPTY WEIGHT	192,215 kg	192,559 kg
MAXIMUM PAYLOAD INCL. EQUIPMENT WEIGHT	120,000 kg	150,000 kg
MAXIMUM LANDING WEIGHT	330,000 kg	360,000 kg
MAXIMUM ZERO FUEL WEIGHT	306,000 kg	335,000 kg
CRUISING SPEED	750 km/h	750 km/h
CRUISING ALTITUDE	31,000 – 35,000 ft	31,000 – 35,000 ft
RANGE	4,500 km	4,500 km
MAXIMUM SINGLE LIFT WITH INTERNAL CRANES	20,000 kg	20,000 kg
ENGINEERING CREW	7 crew members	7 crew members
FLIGHT CREW	6 crew members	6 crew members

### DRAWING OF AIRCRAFT

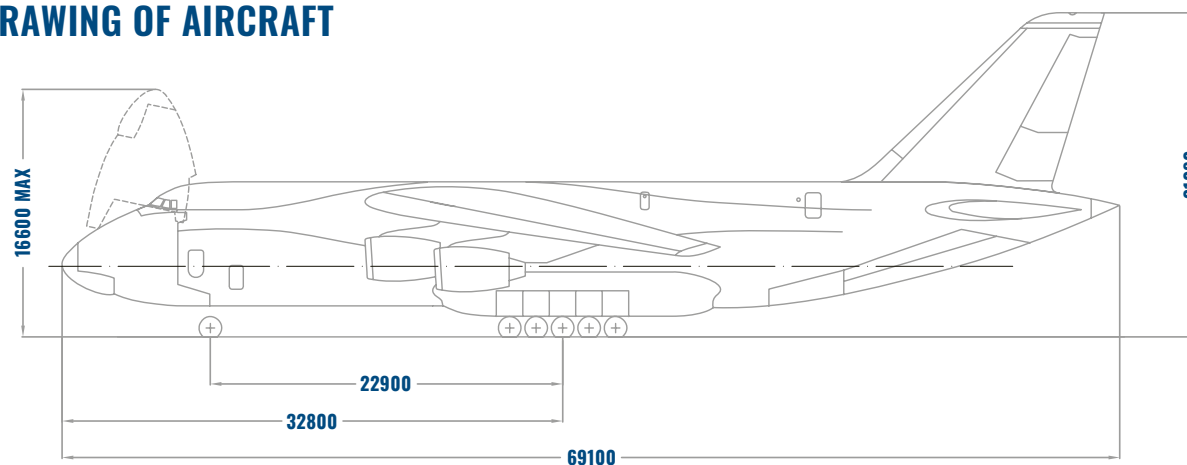



## ✈️ AIRCRAFT SPECIFICATION

# AN-124-100/150

### CARGO CAPABILITIES

Loadplan

Dimensions: L 36.5 m x W 6.4 m x H 4.4 m

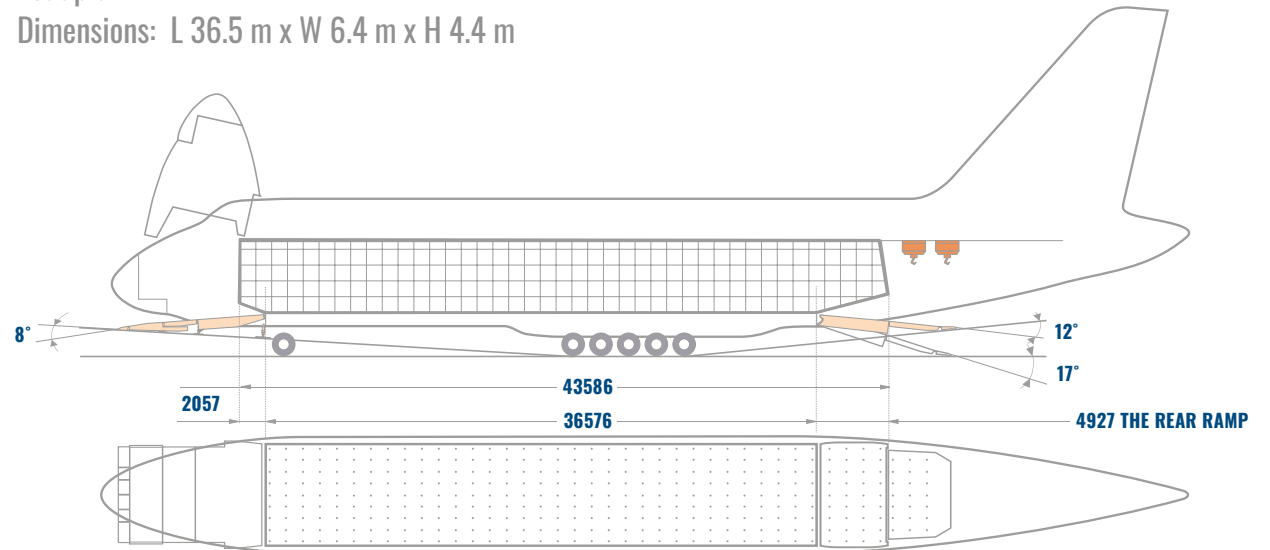

PAYLOAD INCL. EQUIPMENT WEIGHT

# 120,000/ 150,000 kg

RANGE

# 4,500/ 2,300 km

### LOADING METHODS

- Pallets & crates loaded by forklift
- Use of the internal crane system
- Vehicles driven or winched into the aircraft
- Vehicles loaded on the Car Rack System
- Heavy or outsized items winched into the aircraft using the tracking system

### CROSS SECTION

Frame No. 20

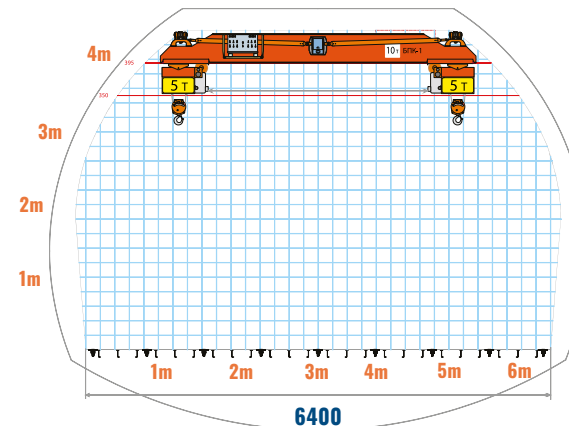

## ENVIRONMENT IN THE CARGO CABIN

### G-Factors

- Forward ▶ 2.3g
- Backward ▶ 1.5g
- Lateral ▶ 1.5g
- Upward ▶ 2.0g
- Down ▶ 2.5g

The lashing and preparation of cargo for flights must be done in respect of these maximum values.

### AIR PRESSURE

- Minimum pressure (unpressurised cargo cabin) ▶ 260 mbar
- Minimum pressure (pressurised cargo cabin) ▶ 480 mbar +0/1/-0.02 kg/cm<sup>2</sup>
- Air pressure change rate ▶ 70 mbar/min

### TEMPERATURE RANGE

- Air Temperature ▶ Up till 20° C upon request
- Humidity during flight ▶ 10-15% RH

## ✈️ AIRCRAFT SPECIFICATION

# AN-124-100/150

### DRAWING OF AIRCRAFT

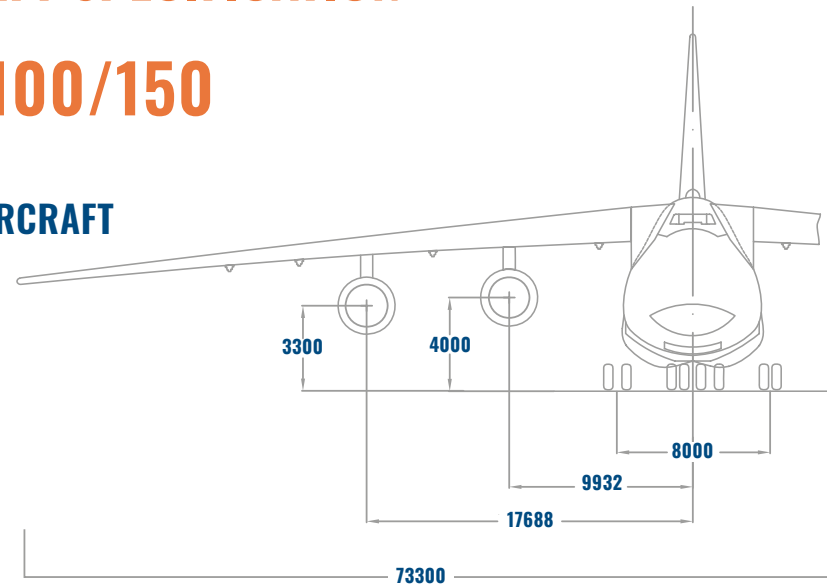

### LOADING EQUIPMENT

- **Internal Crane System** consists of two gantries each with two lifting hooks. Capable of lifting single items of up to 20,000 kg. The containers must have suitable lifting points. The SPG system can be fitted to increase lifting capacity up to 30,000 kg but has further restrictions relating to the centre of gravity of the container and location of lifting points.
- **Double-deck loading and transport system** designed and patented by Volga-Dnepr allows the An-124-100 to transport up to 35 cars (average sedan) on a single flight; loading does not require any additional equipment; alternatively, cars can be driven or winched through the nose
- **Bearings** for elements of the front aircraft ramp or, to put it simply, under the front ramp of the An-124
- **Extension ramps** of various types of cargo
- **Tracking systems** (similar to railway tracks): **2 versions:** low-profile and standard-profile
- **Skate beams and roller beams**
- **Platforms** of various design and load-carrying capacity
- **Protective weight-distributing plating**





## AIRCRAFT SPECIFICATION

# IL-76TD-90VD

Volga-Dnepr participated in the cross-section modernisation of the IL-76TD, **one of Volga-Dnepr's most successful cargo aircraft** thanks to its cabin size, carrying capacity and autonomous loading capabilities.

The resulting product is the IL-76TD-90VD, equipped with new PC-90A-76 engines and modern avionics, approved for worldwide operations.

### IL-76TD-90VD

ENGINE TYPE	4x PS-90A-76
ENGINE TAKE-OFF THRUST	4x 16,000 kg f $\Sigma$ = 64,000
MAXIMUM TAKE-OFF WEIGHT	195,000 kg
OPERATING EMPTY WEIGHT	97 243 kg
MAXIMUM PAYLOAD INCL. LOADING EQUIPMENT	50,000 kg
MAXIMUM LANDING WEIGHT	155,000 kg
MAXIMUM ZERO FUEL WEIGHT	144,800 kg
CRUISING SPEED	750 km/h
FLIGHT LEVEL (TYPICAL)	9,100 m – 10,600 m
RANGE	4,500 km
CAPABILITY OF ONBOARD CRANE SYSTEM	12,000 kg
ENGINEERING CREW	4 crew members
FLIGHT CREW	4 crew members

### DRAWING OF AIRCRAFT

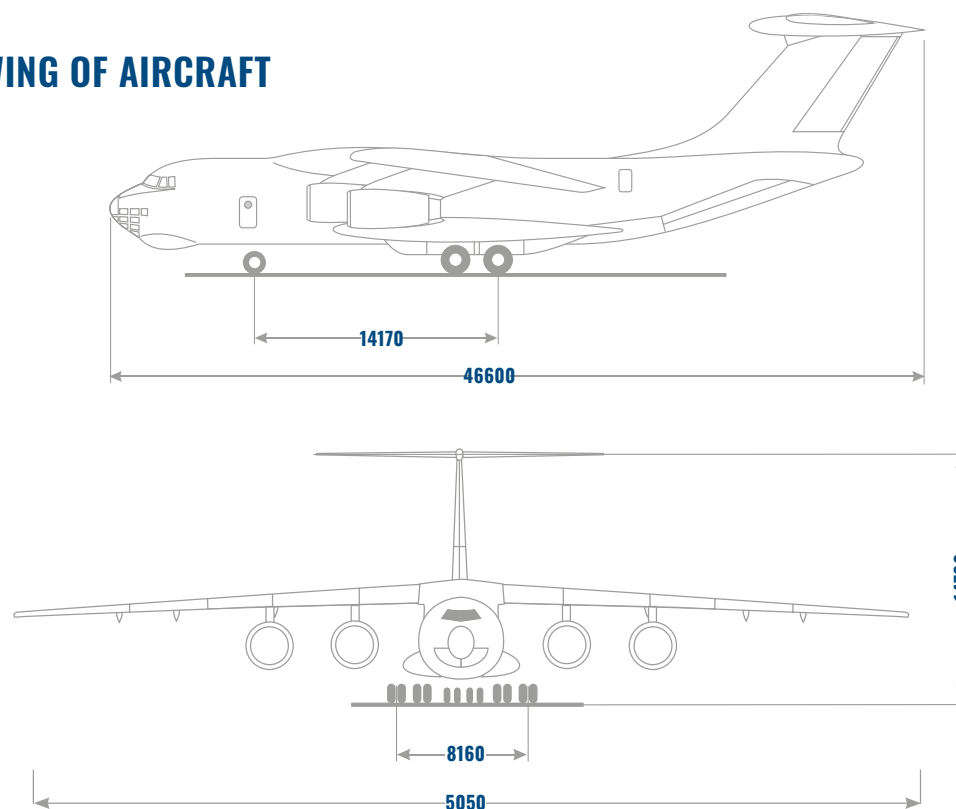

## ✈️ AIRCRAFT SPECIFICATION

# IL-76TD-90VD

### CARGO CAPABILITIES

Loadplan

Dimensions: L 18.5 m x W 3.4 m x H 3.25 m

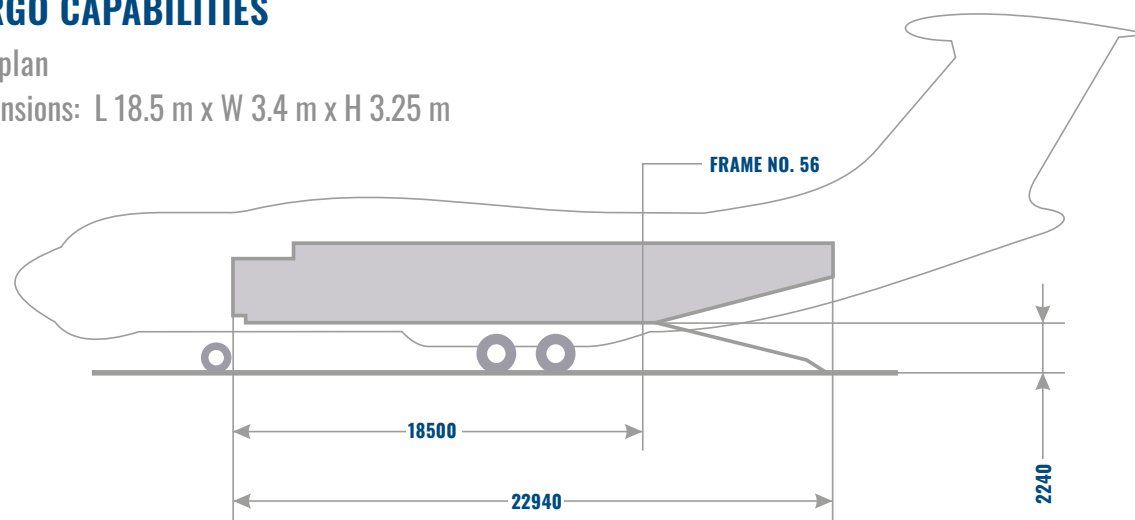

### CROSS SECTION

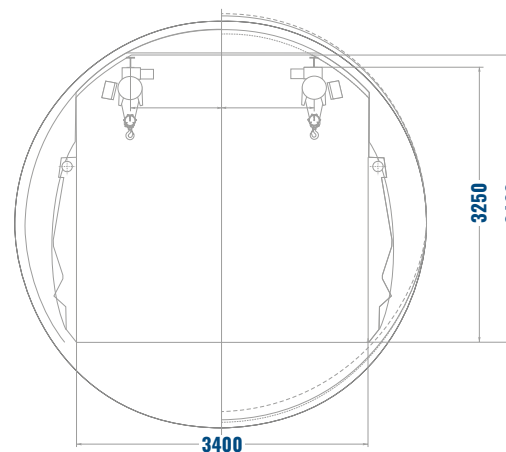

MAX. LANDING WEIGHT

# 195,000 kg

PAYLOAD INCL. EQUIPMENT WEIGHT

# 50,000 kg

RANGE

# 4,500 km

CRUISING SPEED

# 750 km/h



## ✈️ AIRCRAFT SPECIFICATION

### IL-76TD-90VD

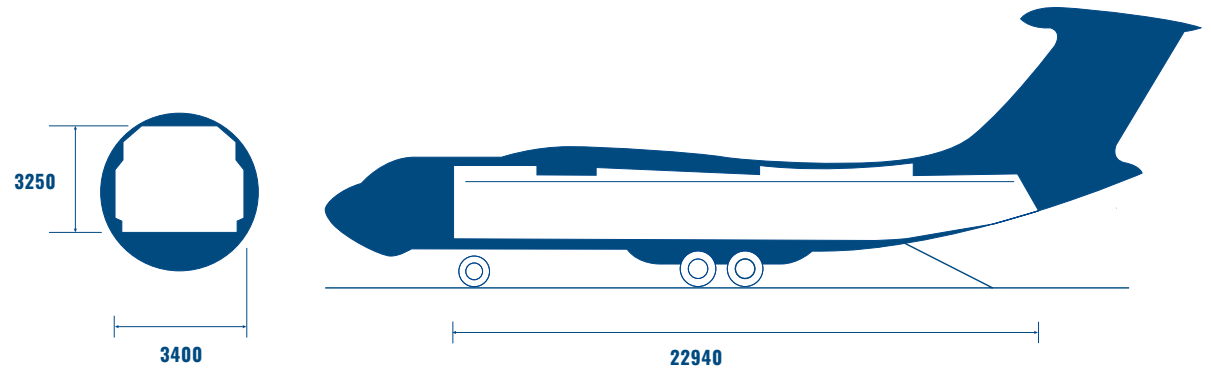

## ENVIRONMENT IN THE CARGO CABIN

### G-Factors

- Forward ▶ 2.23g  
(up to 6.0g in case of emergency landing)
- Backward ▶ 1.5g
- Lateral ▶ 1.5g
- Upward ▶ 2.0g
- Down ▶ 2.5g

The lashing and preparation of cargo for flights must be done in respect of these maximum values.

### AIR PRESSURE

- Maximal pressure  
▶ 750 mbar (2 500m)
- Air pressure change rate  
▶ 15 mbar/min

### TEMPERATURE RANGE

- Air Temperature  
▶ Up till 25° C upon request
- Humidity during flight  
▶ 10-15% RH

### LOADING EQUIPMENT

- Internal Crane System – The onboard system of overhead cranes consists of 4 electric hoists with 3-tonne lifting capacity each, they are capable of lifting single items of up to 12,000kgs
- The freighter is equipped with 2 onboard electric winches of 3-tonne hauling capacity each
- Loading of wheeled vehicles, trailers and tracked vehicles
- Ramp enables wheeled vehicles to be loaded using their own power
- Extension ramp can be applied for the loading of long and high vehicles
- Loading of heavy and outsize cargo
- Use of special Volga-Dnepr Airlines' loading equipment for loading of heavy and outsize cargo subject to usage of mobile crane(s) and additional trailers



# ✈️ AIRCRAFT SPECIFICATION

## BOEING 747-8F/400ERF

The Boeing 747 is an all-cargo aircraft and is **one of the most popular choices for cargo transportation.** Its unique features such as the large side door and nose door facilitate the ease and flexibility of loading.

### BOEING 747-8F

MAXIMUM TAKE-OFF WEIGHT	447,695 kg / 986,998 lb
MAXIMUM LANDING WEIGHT	346,090 kg / 762,997 lb
MAXIMUM PAYLOAD INCL. EQUIPMENT	139,000 kg
MAIN DECK VOLUME	727 m <sup>3</sup> / 25,674 ft <sup>3</sup>
LOWER HOLD VOLUME	206,6 m <sup>3</sup> / 7,296 ft <sup>3</sup>
BULK	14 m <sup>3</sup> / 496 ft <sup>3</sup>
ULD MAIN DECK	34 positions

### BOEING 747-400ERF

MAXIMUM TAKE-OFF WEIGHT	412,769 kg / 910,000 lb
MAXIMUM LANDING WEIGHT	296,195 kg / 653,000 lb
MAXIMUM PAYLOAD INCL. EQUIPMENT	116,500 kg
MAIN DECK VOLUME	653 m <sup>3</sup> / 23,061 ft <sup>3</sup>
LOWER HOLD VOLUME	157 m <sup>3</sup> / 5,544 ft <sup>3</sup>
BULK	14 m <sup>3</sup> / 520 ft <sup>3</sup>
ULD MAIN DECK	30 positions

### DRAWING OF AIRCRAFT

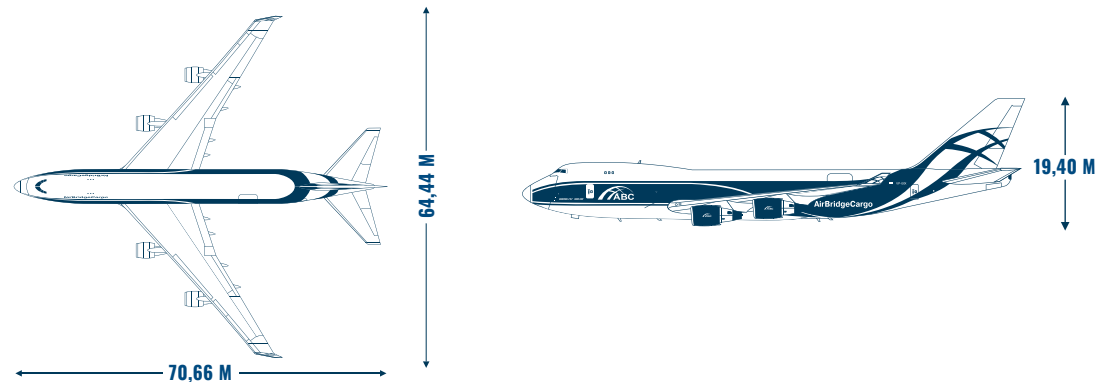
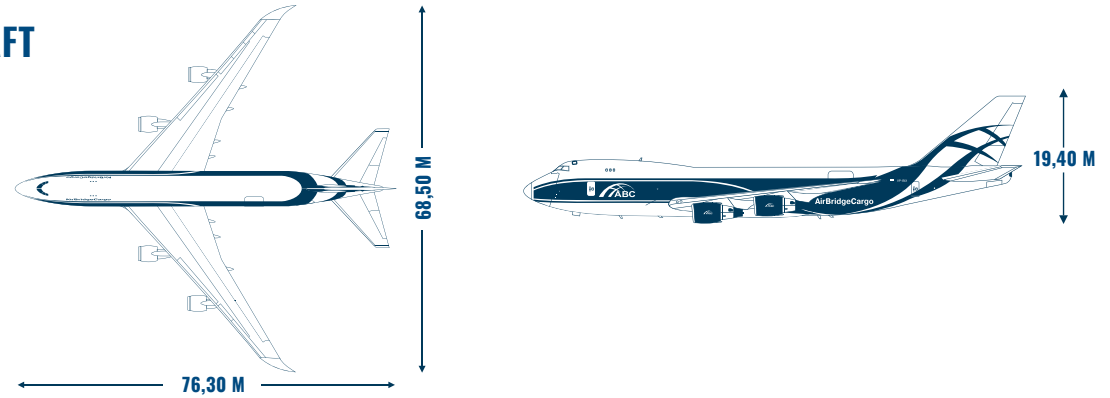

The Boeing 747-8F and 747-400ERF both contain three compartments enabling different temperature settings from 4°C to 29°C.



## ✈️ AIRCRAFT SPECIFICATION

# BOEING 747-8F/400ERF

### DRAWING OF AIRCRAFT

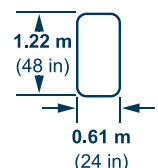
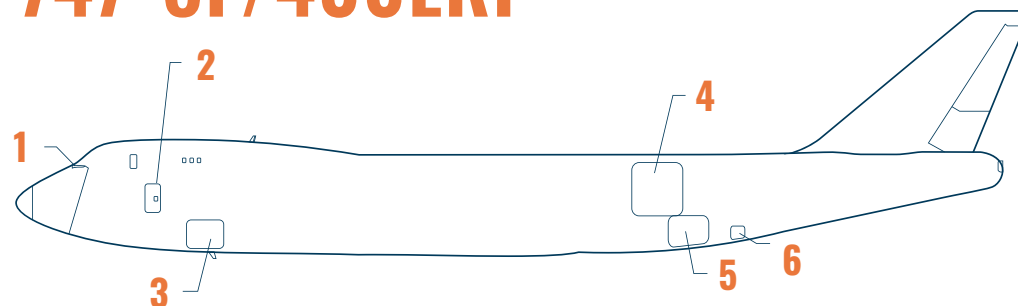

**U/D entry door (STA 464)**  
Left-hand side

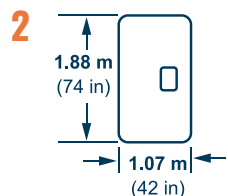

**Fwd crew service door (STA 464)**  
Left-hand side

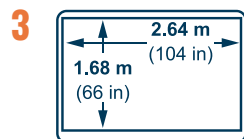

**Fwd lower deck cargo door (STA 615)**  
Right-hand side

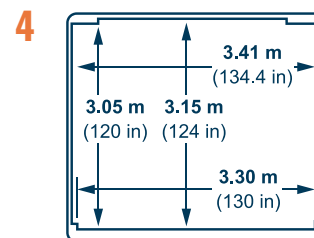

**Main deck cargo door (STA 1770)**  
Left-hand side

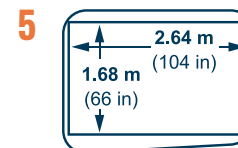

**Aft lower deck cargo door (STA 1865)**  
Right-hand side

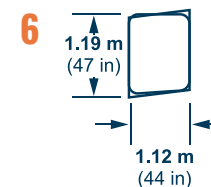

**Bulk cargo door (STA 2007)**  
Right-hand side

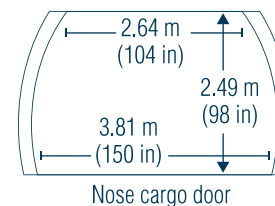
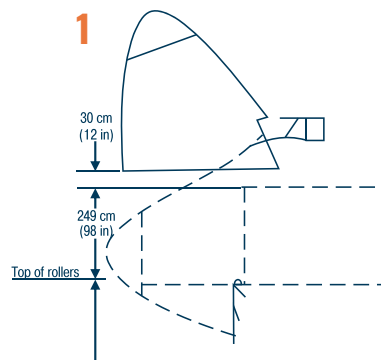
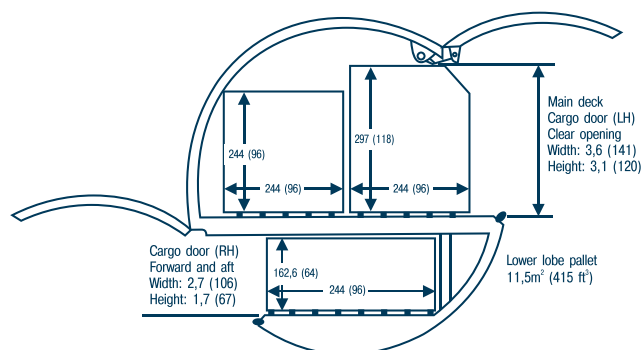

**Nose cargo door**

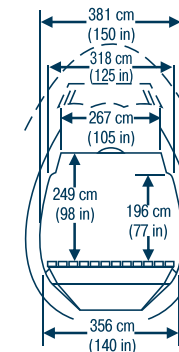



## ✈️ AIRCRAFT SPECIFICATION

# BOEING 747-8F/400ERF

## ULDs

### PYB

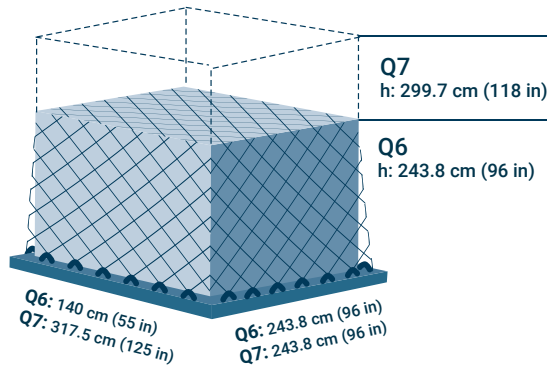

### PGA/PGF

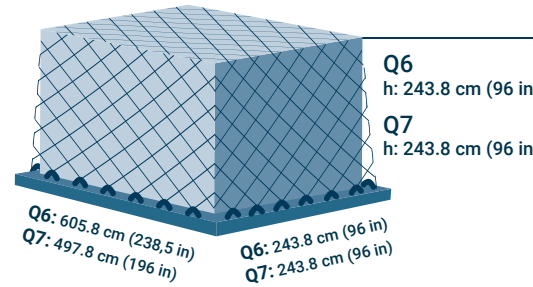

### AKE

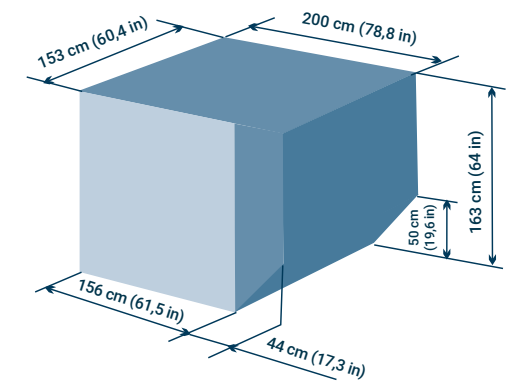

### PMC

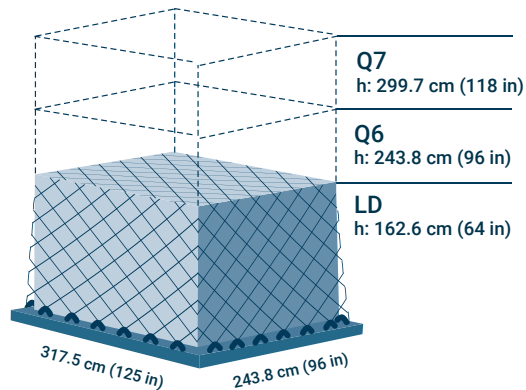

### PZA

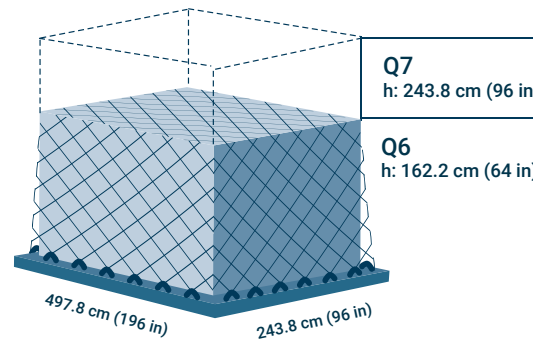



# ✈️ AIRCRAFT SPECIFICATION

## BOEING 777F

The Boeing 777 is the **world's largest, most capable twin-engine freighter** and offers 102 tonnes of payload. This aircraft as an ideal complement to our B747F family allowing us to provide a more sustainable and efficient service. Advanced technology including a new composite wing, all-new engines and superior aerodynamics will result in enhanced benefits for our customers.

### DRAWING OF AIRCRAFT

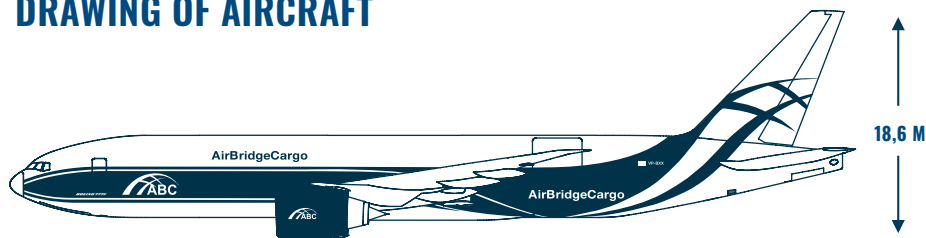

### BOEING 777F

<b>MAXIMUM TAKE-OFF WEIGHT</b>	<b>349,720 kg / 766,800 lb</b>
<b>MAXIMUM PAYLOAD INCL. EQUIPMENT</b>	<b>106,410 kg / 234,594 lb</b>
<b>RANGE</b>	<b>9,200 km / 4,970 nmi</b>
<b>CRUISE SPEED</b>	<b>Mach 0.84</b>
<b>TOTAL CARGO VOLUME</b>	<b>652.7 m<sup>3</sup> / 23,051 ft<sup>3</sup></b>
<b>ULD MAIN DECK</b>	<b>27 positions</b>

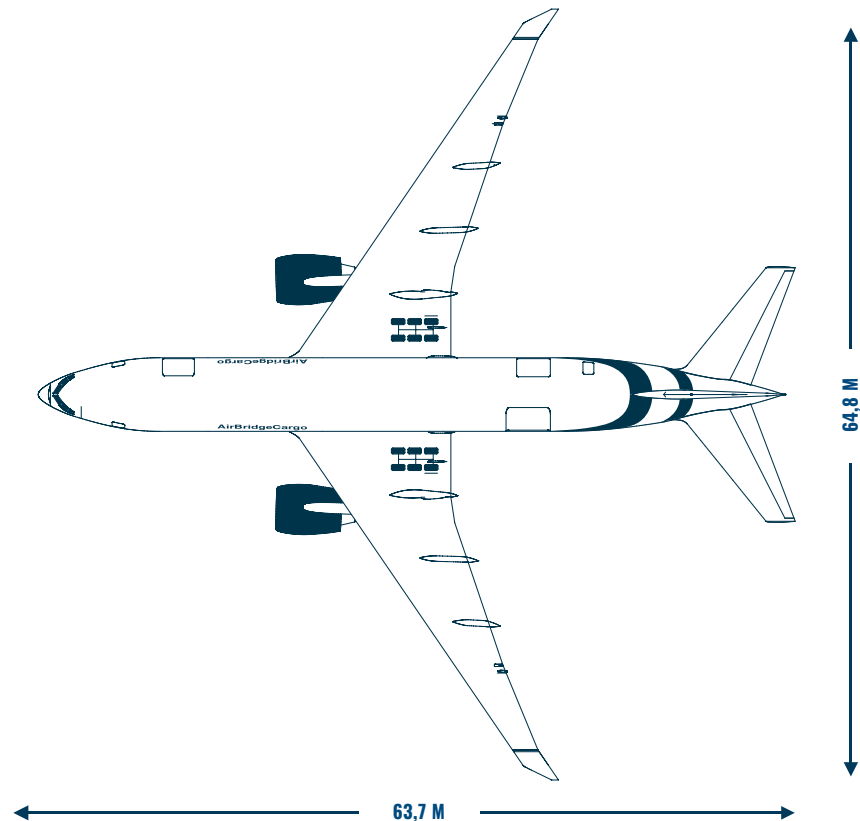



# AIRCRAFT SPECIFICATION

## BOEING 777F

### CARGO CAPABILITIES

#### Main deck

518.2 m<sup>3</sup> (18,301 ft<sup>3</sup>)

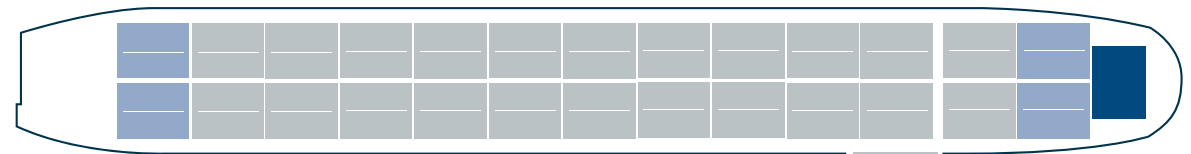

(22) 96-in x 125-in x 10-ft  
contoured pallets  
19.5 m<sup>3</sup> (690 ft<sup>3</sup>)

(4) 96-in x 125-in x 116-in  
contoured pallets  
17.8 m<sup>3</sup> (627 ft<sup>3</sup>)

(1) 96-in x 125-in x 8-ft pallet  
17.4 m<sup>3</sup> (613 ft<sup>3</sup>)

#### CROSS SECTION

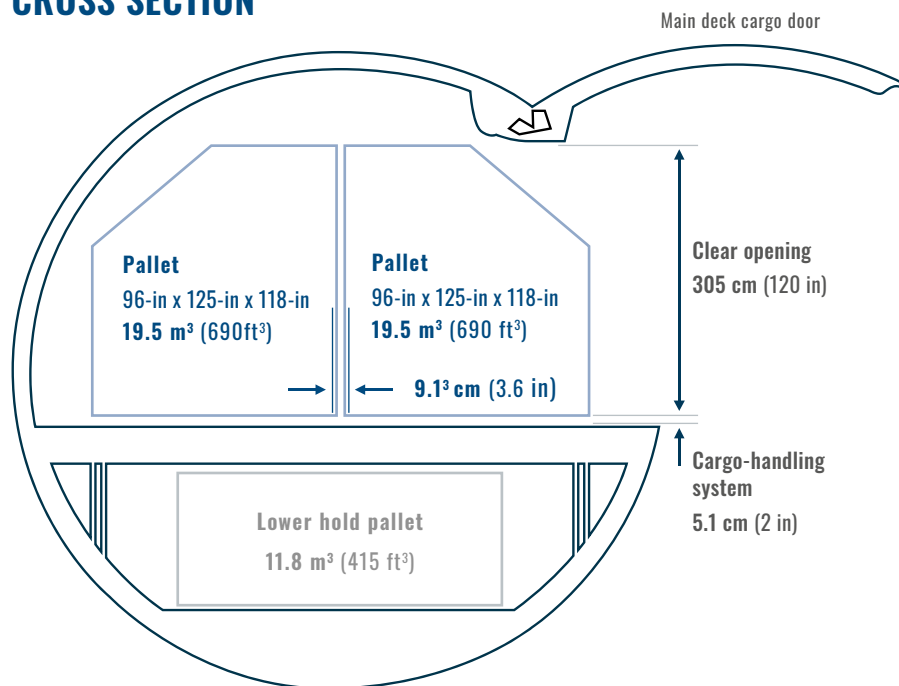

#### Forward lower hold

70.5 m<sup>3</sup> (2,490 ft<sup>3</sup>)

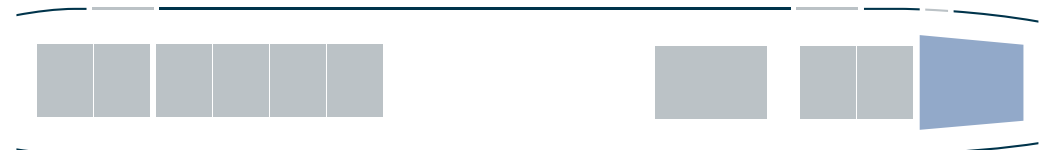

(10) 96-in x 125-in x 64-in pallets  
11.8 m<sup>3</sup> (415 ft<sup>3</sup>)

Bulk 17.0 m<sup>3</sup> (600 ft<sup>3</sup>)

#### Aft lower hold

47.0 m<sup>3</sup> (1,660 ft<sup>3</sup>)





## ✈️ AIRCRAFT SPECIFICATION

# BOEING 737

The Boeing 737-400SF/800BCF is a twin-engine medium-haul aircraft that is **perfectly suited to short and mid-range routes.**

It is able to carry up to 20 tons and 130 m<sup>3</sup> of cargo to a distance of 2,800 kilometres. The aircraft is equipped with a main deck side cargo door and a loading system enabling it to stow 10 standard 2235×3175 mm aviation pallets and containers in the cargo hold.

### BOEING 737-800BCF

MAXIMUM TAKE-OFF WEIGHT	79,000 kg / 174,200 lb
MAXIMUM LANDING WEIGHT	66,350 kg / 146,300 lb
MAXIMUM PAYLOAD INCL. EQUIPMENT	23,950 kg
MAIN DECK VOLUME	141,5 m <sup>2</sup> / 4,997 ft <sup>3</sup>
PALLETS AND CONTAINERS WITH BASE 88" X 125", TOTAL NUMBER	11

### BOEING 737-400SF

MAXIMUM TAKE-OFF WEIGHT	65,090 kg / 153,500 lb
MAXIMUM LANDING WEIGHT	55,338 kg / 122,000 lb
MAXIMUM PAYLOAD INCL. EQUIPMENT	20,000 kg
MAIN DECK VOLUME	121,5 m <sup>2</sup> / 4,289 ft <sup>3</sup>
PALLETS AND CONTAINERS WITH BASE 88" X 125", TOTAL NUMBER	10+1

### DRAWING OF AIRCRAFT

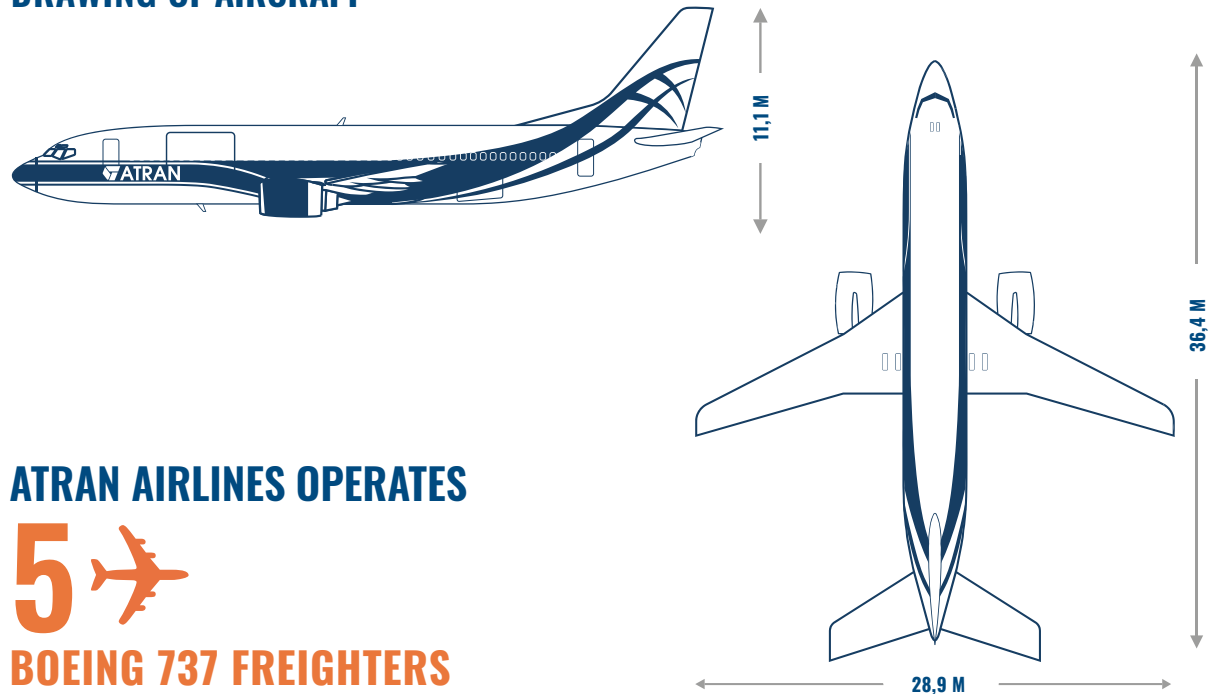

### ATRAN AIRLINES OPERATES

# 5 ✈️

### BOEING 737 FREIGHTERS

## ✈️ AIRCRAFT SPECIFICATION

# BOEING 737-400SF/800BCF

### CARGO CAPABILITIES

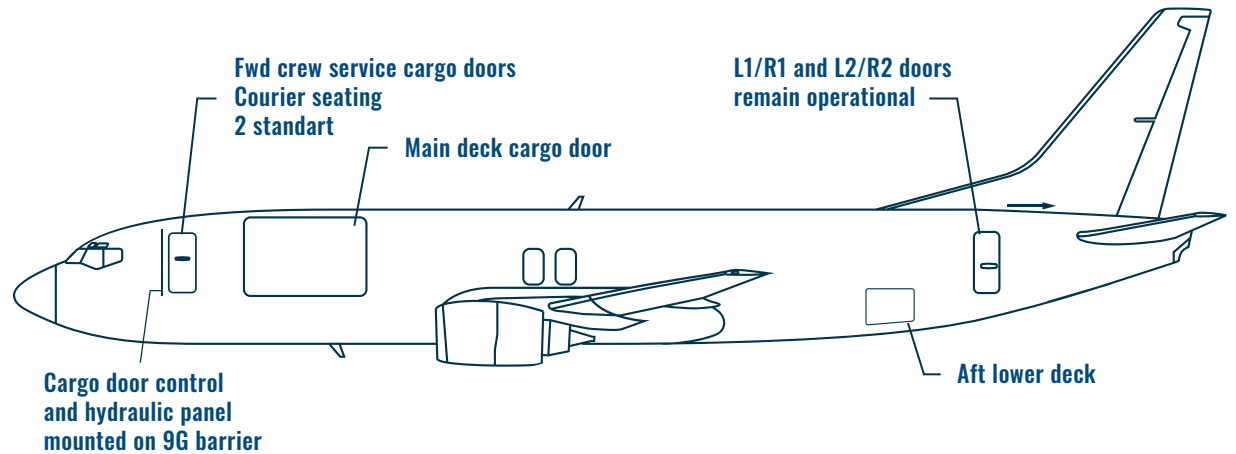

### CARGO CAPABILITIES

#### Dimensions

- Boeing 737-400SF
- Length 36.4 m / 119 ft
- Height 11.07 m / 36 ft
- Wing span 28.88 m / 94 ft
- Boeing 737-800BCF
- Length 39.5 m / 128 ft
- Height 12.54 m / 39.4 ft
- Wing span 35.8 m / 114.8 ft

#### MAX. TAKE OFF WEIGHT

**65,090 kg**  
**153,500 lb**

#### MAX. LANDING WEIGHT

**55,338 kg**  
**122,000 lb**

#### MAIN DECK VOLUME

**121,5 m<sup>2</sup>**  
**4,289 ft<sup>3</sup>**

#### MAX. WEIGHT FOR ONE PIECE OF CARGO

**3,200 kg**



## ✈️ AIRCRAFT SPECIFICATION

# BOEING 737-400SF/800BCF

### CARGO CAPABILITIES

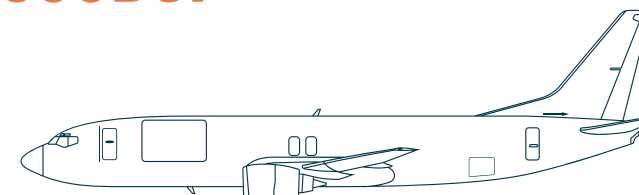

### LOADING HEAVY CARGO

- The maximum weight for one piece of cargo is 3,200kg, on the condition that the dimensions of this piece do not exceed the dimensions of the pallet
- With a new scheme developed by ATRAN Airlines, should the cargo not exceed dimensions of 200 x 140 x 150cm, the weight of the cargo can be up to 6t

### LOADING METHODS

- Loading oversized cargo (Main deck)
- Dimensions up to 380 x 100 x 100cm and must be reinforced on a pallet and loaded by the wide side of the pallets, turning 90 degrees on entrance to the main deck
- Loading cargo at an angle to the door of the main cargo decking

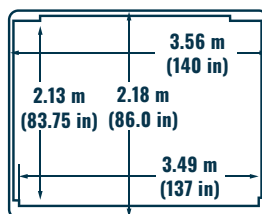

Main deck cargo deck

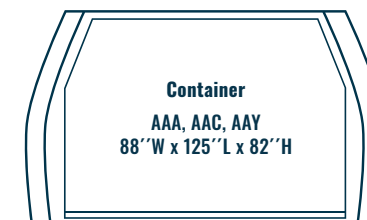
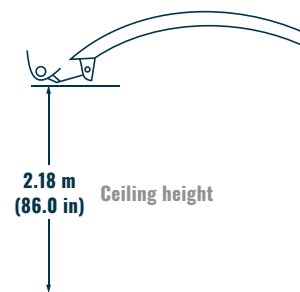

Position 1-10

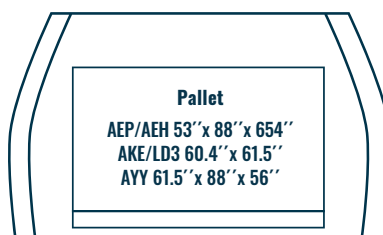

Position 11

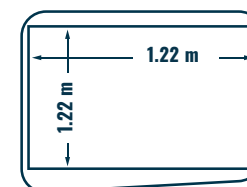

Aft lower deck cargo door

# CONTACT US



**Volga**  **Dnepr**

## **London Heathrow, United Kingdom**

+44 1279 661 166

europa.sales@volga-dnepr.com

## **Ulyanovsk, Russia**

+7 8422 590059

sales@volga-dnepr.com

## **Houston (Texas), USA**

+1 832 585 8611

americas.sales@volga-dnepr.com

## **Sharjah, UAE**

+9 716 557 0833

imea.sales@volga-dnepr.com

## **Beijing, China**

+86 10 8447 5502

apac.sales@volga-dnepr.com

## **Hong Kong, China**

+852 2126 7251

apac.sales@volga-dnepr.com

## **Tokyo, Japan**

+81 3 3578 3320

apac.sales@volga-dnepr.com



## **Head office: Moscow, Russia**

+7 495 7862613

info@airbridgecargo.com

service.rus@airbridgecargo.com

## **Frankfurt am Main, Germany**

+49 69 638097 100

service.fra@airbridgecargo.com

sales.fra@airbridgecargo.com

## **Amsterdam, Netherlands**

+31 20 654 9030

service.ams@airbridgecargo.com

sales.ams@airbridgecargo.com

## **Chicago, USA**

+1 773 800 2361

abcsales.ord@airbridgecargo.com

service.usa@airbridgecargo.com

## **Atlanta, USA**

+1 404 7663545

abcsales.atl@airbridgecargo.com

service.atl@airbridgecargo.com

## **Beijing, China**

+86 10 8447 5936/37/38

service.pek@airbridgecargo.com

## **Hong Kong, China**

+852 2215 3928

service.hkg@airbridgecargo.com

## **Shanghai, China**

+86 21 5208 0011

service.pvg@airbridgecargo.com

**ATRAN**

## **Moscow, Russia**

+7 495 755 68 50

sales@atran.ru

[WWW.VOLGA-DNEPR.COM](http://WWW.VOLGA-DNEPR.COM)

[WWW.AIRBRIDGECARGO.COM](http://WWW.AIRBRIDGECARGO.COM)

[WWW.ATRAN.RU/EN/](http://WWW.ATRAN.RU/EN/)