

WE DELIVER FOR

AUTOMOTIVE

LEADERS

Volga  Dnepr

WE WORK WITH WORLD LEADERS

For over 28 years, Volga-Dnepr Group has been advancing the world of air logistics, enabling our global customers to achieve fast, secure and cost efficient transportation solutions, even for their most complex logistics challenges.

Our international reputation has been built on helping our customers to plan effectively, respond quickly and, most importantly of all, keep the promise they have made to their own customers. That's why so many of the world's leading companies choose Volga-Dnepr Group as their transportation and logistics partner.

The cargoes we move, for example, help the energy sector provide power to communities across the

globe. We deliver satellites that increase and improve international communications. We help manufacturers and growers ensure a sufficient supply of products and produce to consumers across the globe. We move heavy construction equipment used to support vital infrastructure projects in both the developed and developing worlds. We are also first to react when a man-made or natural disaster endangers lives.



OUR GROUP OF COMPANIES

Volga-Dnepr Group consists of more than 20 companies in nine countries. At the heart of the Group are two core cargo services:

CHARTER OPERATIONS

Global air cargo charter services are provided to the Group's customers by Volga-Dnepr Airlines – the world's largest transporter of outsize and heavyweight air cargo, and the provider of end-to-end engineering and logistics solutions. The Group's air charter capability also includes services using the Ilyushin Il-76TD-90VD, Boeing 747 and B737 freighters in its fleet to offer international customers the most efficient aircraft solution for every charter requirement.

Supporting businesses: Certified Aircraft Maintenance, Repair & Overhaul Centres, Insurance Company, Trucking Services and Volga-Dnepr International Training Centre.

SCHEDULED OPERATIONS

International scheduled cargo services are delivered by AirBridgeCargo Airlines and Atran airlines onboard Boeing 747F and Boeing 737F between Russia, Asia, the Middle East, Europe and North America. Strict on-time performance facilitates seamless transportation, guaranteeing transport connections between continents, countries, and cities.

AirBridgeCargo's fleet consists of 18 Boeing 747 freighters, whereas Atran has three Boeing 737 freighters in operation.

The combined network of both carriers covers more than 40 destinations worldwide, with all flights operated into international cargo hubs, which feature modern equipment, allowing for efficient, seamless, and safe handling of any type of cargo.

OUR FLEET

AN-124-100

✈ x 12

< **120t**
MAX PAYLOAD

- CARGO COMPARTMENT DIMENSIONS 36.5 X 6.4 X 4.4M
- THE AN-124-100 "RUSLAN" IS THE WORLD'S LARGEST SERIES-PRODUCED RAMP AIRCRAFT
- VOLGA-DNEPR IS THE BIGGEST INTERNATIONAL AN-124-100 OPERATOR IN THE WORLD

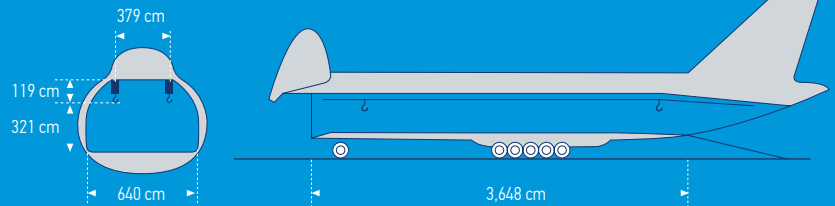

IL-76TD-90VD

✈ x 5

< **50t**
MAX PAYLOAD

- CARGO COMPARTMENT DIMENSIONS 20 X 3.45 X 3.4M
- THE AIRCRAFT IS FULLY COMPLIANT WITH ICAO'S STANDARDS AND IS APPROVED FOR GLOBAL OPERATIONS

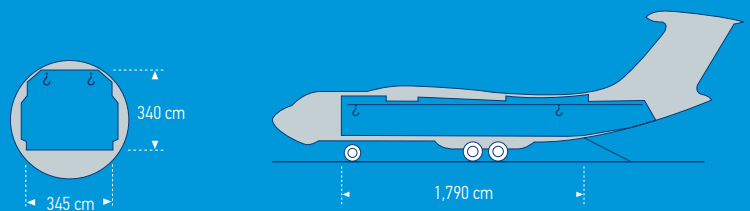

BOEING 747

✈ x 18

46 < **139t**
PALLET CAPACITY MAX PAYLOAD

- IN ADDITION TO SEVEN B747-400 FREIGHTERS, THE GROUP HAS INVESTED IN TEN NEXT GENERATION B747-8F, THE MOST ADVANCED CARGO AIRCRAFT OF ITS TYPE EVER BUILT BY BOEING
- THE 747 IS ESPECIALLY WELL-SUITED FOR SHIPMENTS REQUIRING STRICT TEMPERATURE SUSTAINABILITY

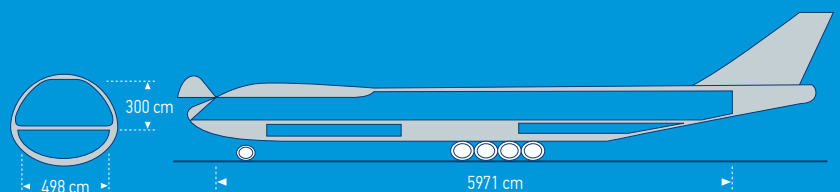

BOEING 737

✈ x 3

10 < **20t**
PALLET CAPACITY MAX PAYLOAD

- THE GROUP'S THREE BOEING 737 FREIGHTERS PROVIDE REGIONAL CARGO LIFT AND ARE USED AS PART OF VOLGA-DNEPR'S "CARGO SUPERMARKET" SERVICE OFFERING ALONGSIDE THE REST OF THE FLEET

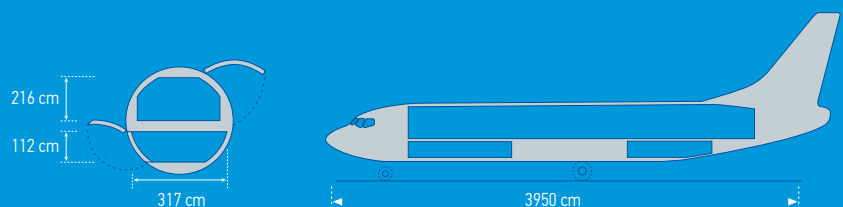

THE AIRLINE FOR AUTOMOTIVE LEADERS

SINCE 1990, THE AUTOMOTIVE INDUSTRY HAS REPRESENTED ONE OF VOLGA-DNEPR GROUP'S STRONGEST CUSTOMER SECTORS



> **950**

flights for Automotive customers to date



> **62,000**

tonnes of cargo delivered

THE PROCESS OF MOVING YOUR CARGO

Once we receive your request, the delivery of your cargo is managed through 8 key stages:

- 1** Development of logistics solutions
- 2** Load planning
- 3** Commercial & navigation checks
- 4** Cost calculation
- 5** Optimal option agreement & contract
- 6** Preparation of your cargo
- 7** Transportation
- 8** Post flight liaison

OUR EXPERTS ARE READY TO ASSIST YOU 24/7



AUTOMOTIVE GLOBAL EXPERTISE MAP

950
✈️ FLIGHTS*

62,000
📦 TONNES CARRIED*

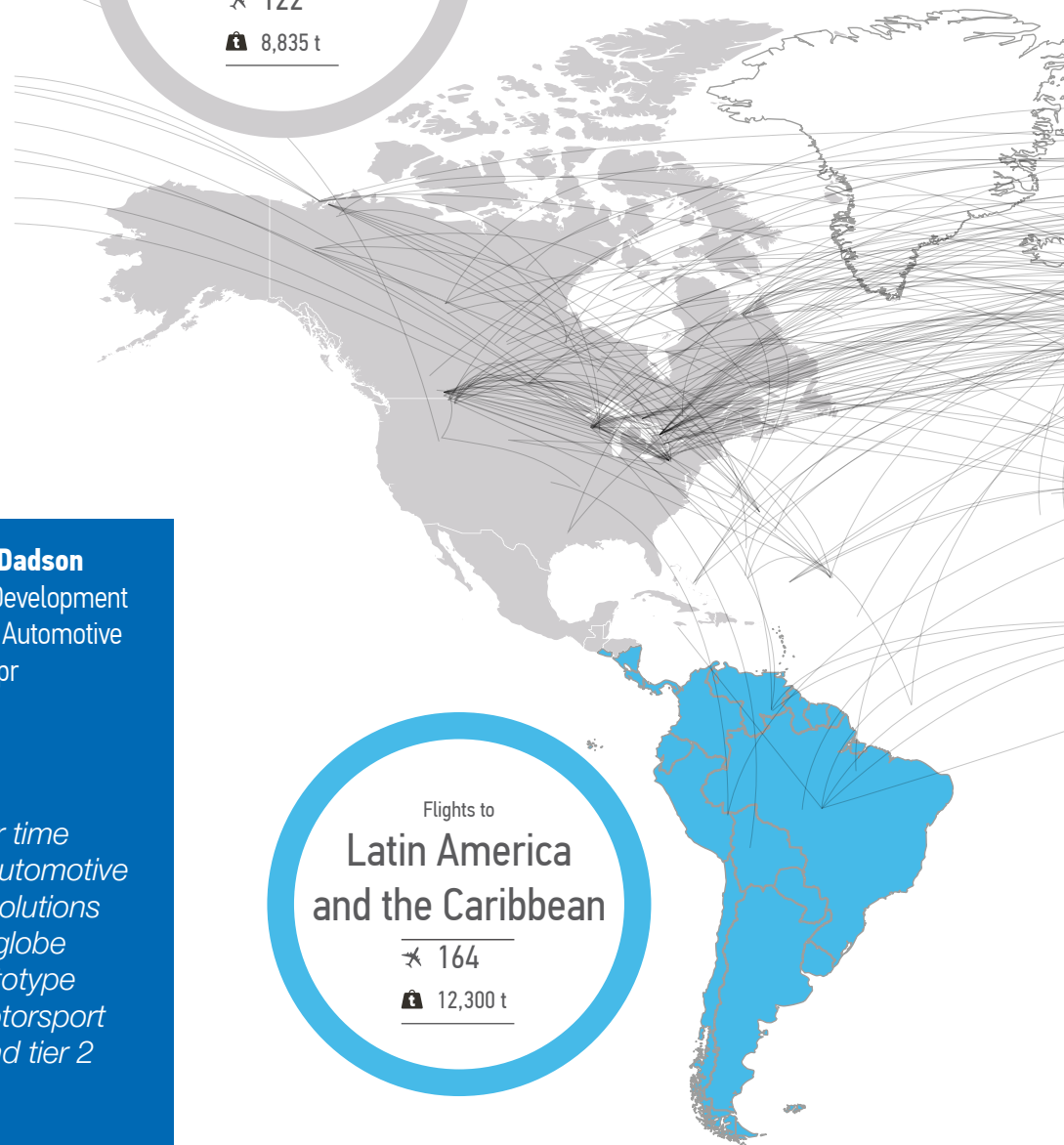
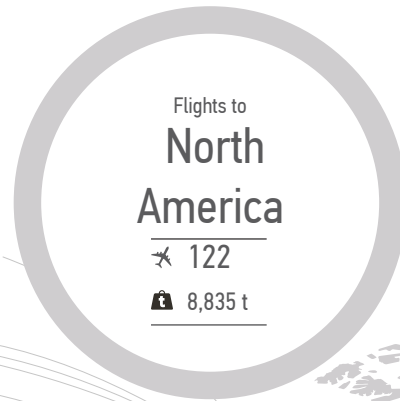

Matthew Dadson
Business Development
Manager - Automotive
Volga-Dnepr

"Volga-Dnepr has time after time shown its expertise in the automotive vertical providing logistics solutions without fail throughout the globe for OEM's finished and prototype vehicles, racing cars for motorsport as well as parts for tier 1 and tier 2 suppliers."

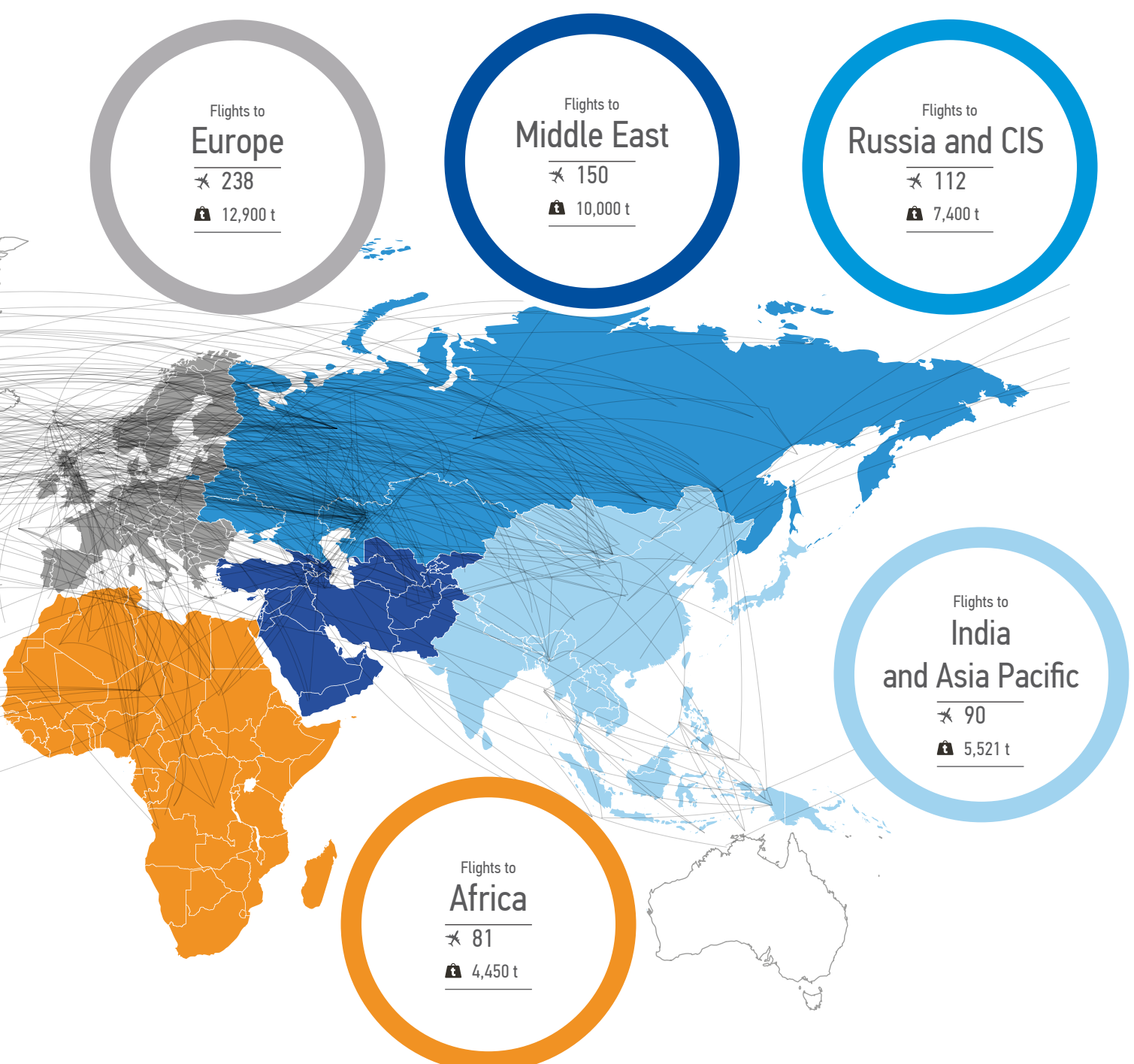

* excluding cargo scheduled operations

CASE STUDY 1

A SAFE HOMECOMING FOR SILK WAY RALLY WINNERS AND COMPETITORS





CARGO DESCRIPTION: SILK WAY RALLY VEHICLES

ROUTE: ASHGABAT (TURKMENISTAN) – LEIPZIG (GERMANY)

WEIGHT: 67,800 KGS

- Volga-Dnepr carried vehicles for teams competing in the Silk Way Rally from Ashgabat to Leipzig.
- Four trucks and 14 jeeps belonging to international teams were flown home onboard an AN-124-100 aircraft, including the winning Volkswagen team in the 'Car' race category.
- As part of its involvement, Volga-Dnepr also provided flight dispatch and support services for the rally's joint flight detachment comprising 13 various aircraft, namely AN-74, AN-74-200, AN-26B, two AN-24, and two Cessna-182, as well as Mi-8P, Mi-8T, AS-355N and AS-350B3 helicopters.

CASE STUDY 2

AIRBRIDGECARGO AND JAS WORLDWIDE FAST TRACK CARS FOR MACAU GRAND PRIX





CARGO DESCRIPTION: RACE VEHICLES

ROUTE: LUXEMBOURG - MACAU (CHINA)

- Race vehicles were delivered to China to compete in the 62nd Macau Grand Prix, one of the most celebrated and respected road races on earth.
- Containers with the cars and their spare parts were transported on AirBridgeCargo's Boeing 747-400F charter flight from Luxembourg to Macau with a technical stop in Moscow.



CASE STUDY 3

VOLGA-DNEPR'S 'CARGO SUPERMARKET' DELIVERS A TOTAL LOGISTICS SOLUTION FOR 51-TONNE TRANSPORTERS TO Khabarovsk





CARGO DESCRIPTION: TWO LARGE SELF-PROPELLED MODULAR TRANSPORTERS

ROUTE: NETHERLANDS - KHABAROVSK (RUSSIA)

WEIGHT: 51,000 KGS

- The delivery of two large self-propelled modular transporters from the Netherlands to Khabarovsk, Russia, has highlighted the value to customers of Volga-Dnepr Group's 'cargo supermarket' transport and logistics capability.
- One of the main challenges facing the Volga-Dnepr team was that the complete shipment could not travel on a single IL-76TD-90VD flight because of its size and weight.
- To provide the most cost efficient, timely and simple delivery, Volga-Dnepr's solution combined an air charter flight using one of its IL-76TD-90VD freighters, the capacity onboard its Boeing 747 scheduled all-cargo services and the expertise of its logistics experts.
- The 51-tonnes of cargo consisted of the two modular transporters measuring 8.7 metres long, 2.4 metres wide and 1.5 metres high, which are used for the transportation of heavy outsize loads, as well as their control station.
- Volga-Dnepr also provided additional services including crane hire, as well as freight handling services at the terminal and on the airport apron.

CARGO SUPERMARKET IN ACTION

VOLGA-DNEPR'S UNIQUE 'CARGO SUPERMARKET' CONCEPT IS DESIGNED TO OFFER CUSTOMERS THE MOST EFFICIENT LOGISTICS SOLUTION FOR EVERY SHIPMENT, TAKING INTO ACCOUNT THE CHARACTERISTICS OF THE CARGO, THE ORIGIN AND DESTINATION POINTS, THE DELIVERY TIMESCALES AND BUDGETARY CONSIDERATIONS.

Over its 28 years of operation, Volga-Dnepr Group has established its reputation as a reliable air carrier, trusted partner, and world leader in the heavy and outsize air cargo transportation market. This achievement is not only due to the unique and unprecedented capabilities of the Group's fleet of airplanes and its development of proprietary loading systems but, more significantly, because of the expertise and professionalism of its team of people who consistently deliver the best transport and logistics solutions for customers worldwide.

Volga-Dnepr Group's proven engineering and logistics expertise enables it to support customers with a total logistics solution for 'door-to-door' deliveries and the completion of complex 'turnkey' projects. This includes the ability to design and manufacture bespoke frames and implement tailored engineering solutions for complex, heavy and outsize cargo deliveries that require the speed, security and

predictability of an air cargo delivery. For every customer requirement, no matter how complex, the Group's logistics specialists are able to call upon the best intellectual and material resources of Volga-Dnepr Group as well as the cooperation of proven and reliable partners and sub-contractors all over the world.

Volga-Dnepr's integrated end-to-end engineering and logistics capabilities are available to the Group's customers whether they require a total door-to-door delivery solution or individual components to ensure a safe, secure and on-time cargo delivery.

Always, our aim is to identify and deliver the most timely, efficient and economic solution for every customer. By discussing your transportation requirements with us at the earliest opportunity in your planning process, we'll deliver the best solution for you.

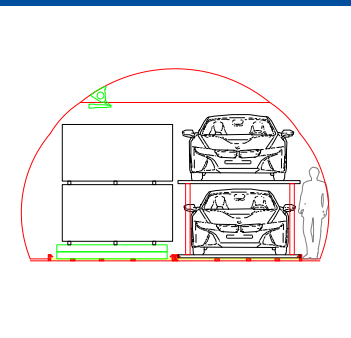

CONSULTANCY, LOGISTICS AND ENGINEERING SERVICES:

Site visits to conduct engineering and technical assessments of cargoes for transportation



Consultancy ahead of the product manufacturing process to ensure the cargo is capable of being transported without any delays or unexpected costs



Design and manufacture of special frames to enable loading and transportation of the cargo



Packaging advice and support to ensure the integrity of the cargo throughout the transportation process



Use of multi-modal services, including road, rail and sea transport



Sourcing of third party cargo aircraft if required to minimise costs for customers



Optimal route planning from production site to final destination



Ground support arrangements at airports for loading/unloading, cargo delivery to/from the airport and obtaining all necessary authorisations, approvals and permits



Assistance with customs clearance, insurance and warehousing of cargo



VOLGA-DNEPR'S ENGINEERING AND LOGISTICS EXPERTS ARE CONTACTABLE 24/7

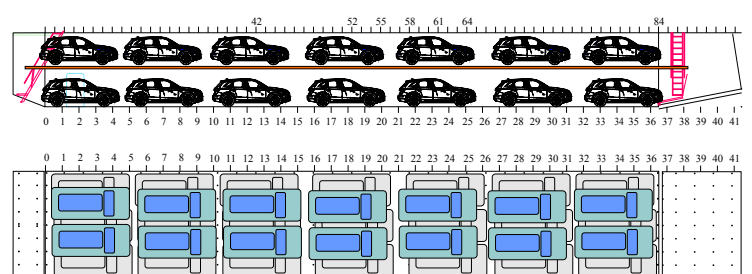
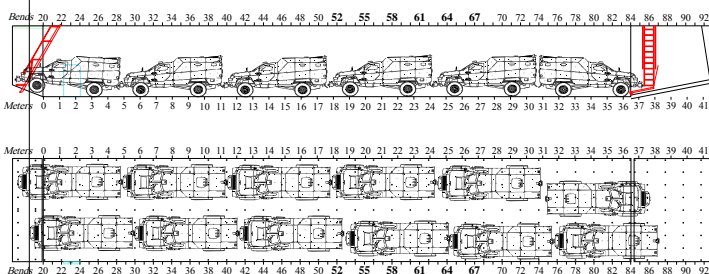

BEST PRACTICE IN MOVING AUTOMOTIVE CARGOES

Over 28 years of growth and development, Volga-Dnepr Group has attracted a highly-educated and highly-skilled workforce capable of tackling every aspect of the transportation and logistics process, however extreme and seemingly 'impossible' the challenge may seem.

Here are some simple steps to help ensure the seamless delivery of your cargo:

1. Provide the airline with any technical drawings and/or photos of the cargo along with any instructions for its transportation. This will allow the load planning engineer to make a full assessment of the cargo and approve loadability prior to shipment.
2. Provide the airline with an accurate list of any additional pieces to be sent with the main cargo. This is required to complete the load planning and navigational calculations.
3. Supply the airline with information on any dangerous goods that may form part of the shipment.
4. Confirm with the airline how the cargo needs to be transported, advising which parts can be dismantled, if required, and explain how the dismantled parts will then be packed.
5. Any enclosed space on the cargo should not be hermetically sealed in order to allow the air pressure inside and outside of the cargo to equalise during the flight.
6. During the flight, the air pressure in the cargo cabin will reduce. It is therefore important to inform the airline if you have any special requirements for the transportation, such as air temperature and pressure in the cargo cabin.
7. Inform the airline of the location of any lifting points and lifting instructions as well as any special requirements.
8. Advise the airline of the locations on the cargo that may be used to adequately secure/restrain the cargo within the aircraft's cargo cabin. The airline will provide a provisional load plan detailing the intended tie-down scheme for your approval.
9. The airline will ask you to approve its planned method for loading and transportation. Please review it and either give consent or explain the reasons for any questions you have and everything possible will be done to find a solution.
10. Talk to the airline if you have any questions or concerns. Solving issues during the preparation stage will avoid any problems or delays to the flight operation.



WHY CUSTOMERS CHOOSE US

VOLGA-DNEPR'S GLOBAL TEAM OF TRANSPORTATION, LOGISTICS AND ENGINEERING SPECIALISTS ARE READY TO SHARE THEIR EXPERTISE WITH YOU.

For over 28 years, we have been proud to serve customers all over the world. They come back to us again and again because they value:

- The expertise of our cargo transportation & logistics experts
- The unique operating capabilities of our aircraft fleet
- Our ability to provide an end-to-end logistics solution
- Our compliance with international safety and security standards
- Our ability to complete individual flights and projects on-time and on-budget
- Our global flight operations, even to remote regions of the world
- Our ability to design and engineer handling and loading frames and systems that make air cargo services possible for unique, outsize and heavyweight cargoes

WHEN TO ENGAGE WITH US

We recommend you contact Volga-Dnepr at the earliest possible stage of your planning process.

For unique, outsize and heavyweight air cargoes, many customers involve Volga-Dnepr at the product design stage in order to ensure that they take transportation of the finished product into account before they begin the manufacturing process. By working in partnership with the customer, Volga-Dnepr's engineering and planning experts can offer advice such as simple modifications to the cargo, if required, that will ensure it can be transported, loaded and unloaded safely. This can result in significant cost and time savings.

Early planning will also help us to ensure the aircraft you need is available when and where you need it to move your shipment on-time.

Volga-Dnepr's unique 'cargo supermarket' services enable us to always find the most cost efficient solution for every cargo movement or project. Talking to us early in your planning and manufacturing cycle means we will be able to tailor our service offering to achieve the optimum transportation of your cargo without having to incur any unnecessary delays or costs.

OUR EXPERTS ARE AT YOUR SERVICE 24/7

CONTACT INFORMATION

VOLGA-DNEPR AIRLINES airline.volga-dnepr.com/en

global.sales@volga-dnepr.com

Stansted, United Kingdom

+44 1279 661 166

europa.sales@volga-dnepr.com

Sharjah, UAE

+9 716 557 0833

imea.sales@volga-dnepr.com

Tokyo, Japan

+81 3 3578 3320

apac.sales@volga-dnepr.com

Ulyanovsk, Russia

+7 8422 590059

sales@volga-dnepr.com

Beijing, China

+86 10 8447 5502

apac.sales@volga-dnepr.com

Hanoi, Vietnam

+844 35810158

han.station@volga-dnepr.com

apac.sales@volga-dnepr.com

Houston (Texas), USA

+1 832 585 8611

americas.sales@volga-dnepr.com

Hong Kong, China

+852 2126 7251

apac.sales@volga-dnepr.com

AIRBRIDGECARGO AIRLINES www.airbridgecargo.com

Head office: Moscow, Russia

+7 495 7862613

info@airbridgecargo.com

service.rus@airbridgecargo.com

Chicago, USA

+1 773 800 2361

abcsales.ord@airbridgecargo.com

service.usa@airbridgecargo.com

Hong Kong, China

+852 2215 3928

service.hkg@airbridgecargo.com

Frankfurt am Main, Germany

+49 69 638097 100

sales.fra@airbridgecargo.com

service.fra@airbridgecargo.com

Dallas, USA

Export: +1 469 629 04 78

Import: +1 214 296 03 74

abcsales.dfw@airbridgecargo.com

service.usa@airbridgecargo.com

Shanghai, China

+86 21 5208 0011

service.pvg@airbridgecargo.com

Amsterdam, the Netherlands

+31 20 654 9030

service.ams@airbridgecargo.com

sales.ams@airbridgecargo.com

Los Angeles, USA

+1 310 258 6100

ext. 3902, 3903, 3904, 3905

abcsales.lax@airbridgecargo.com

service.usa@airbridgecargo.com

Follow us on



YouTube



Edition: 2018

Other brochures available to download:



www.volga-dnepr.com

